

Unit A

1,528 SF – 2 Bedroom – 3½ Bath

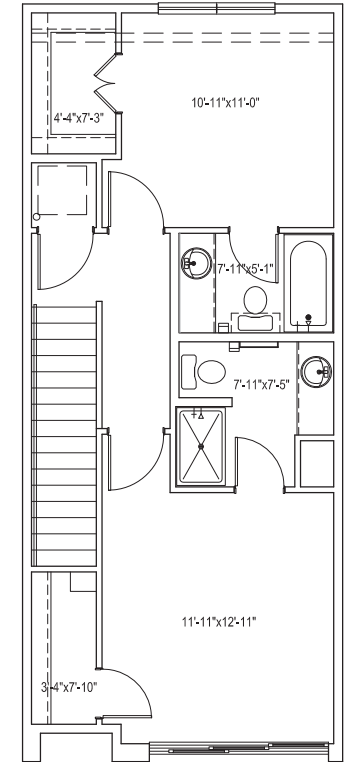
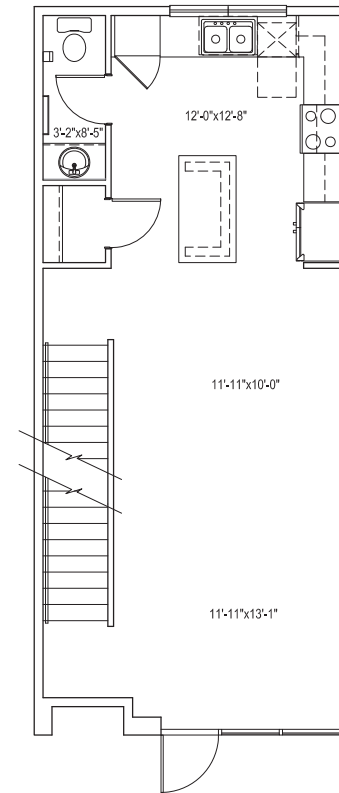
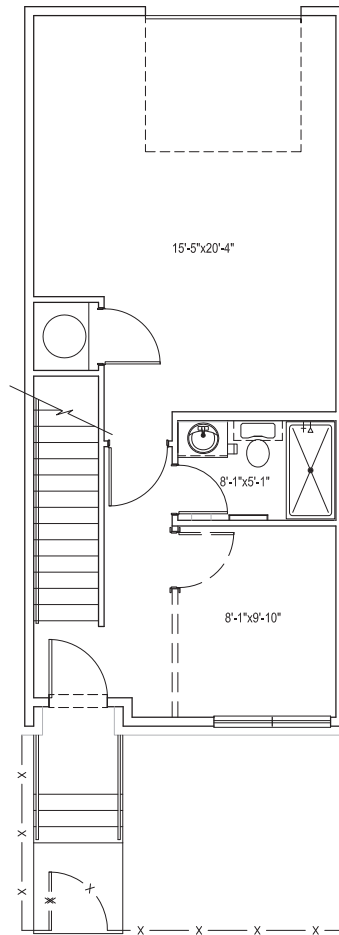
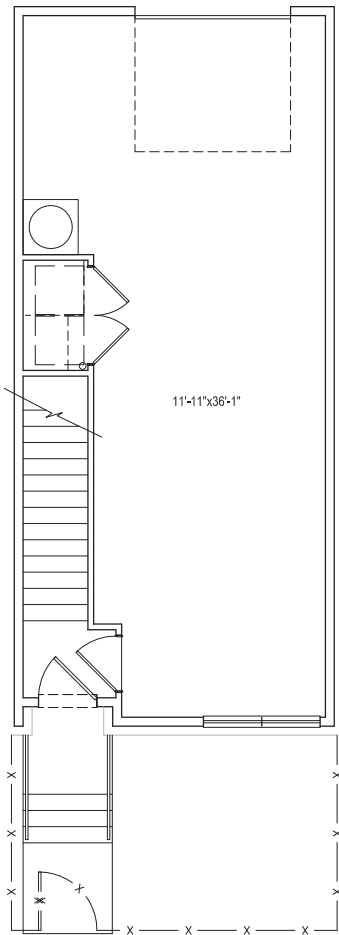

AMENITIES

- True fee simple, townhome ownership for lock and leave living without condo obligations or mortgage restrictions.
- All homes three-stories on individual lots.
- Limited HOA for common area landscaping and maintenance only.
- Sealed concrete first floors with hardwood second and third floors.
- Enclosed garages and storage per plan.
- Elevator capable per plan.
- Full complement of energy saving features.
- Fenced front or rear courtyards, per plan.
- Second and third floor balconies.
- Buyer selected interior finish and appliance packages.
- 9' first floor, 12' second floor and 10' third floor ceiling heights.
- Ample visitor parking.

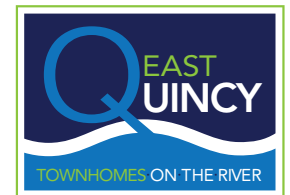

FOR AVAILABILITY
(210) 771-0334

Unit A

Four Story – 1,528 SF – 2 Bedroom – 3½ Bath

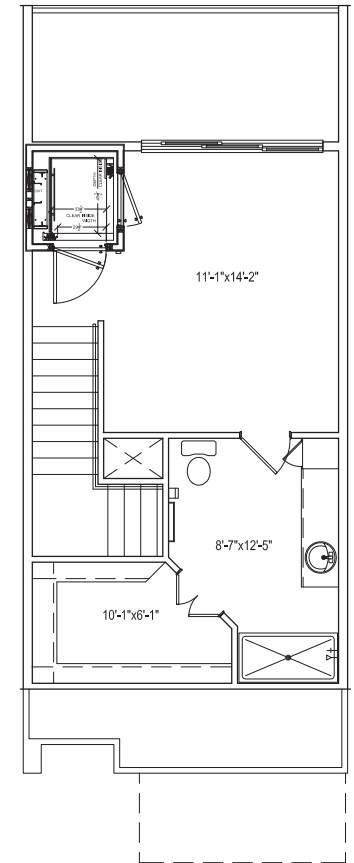
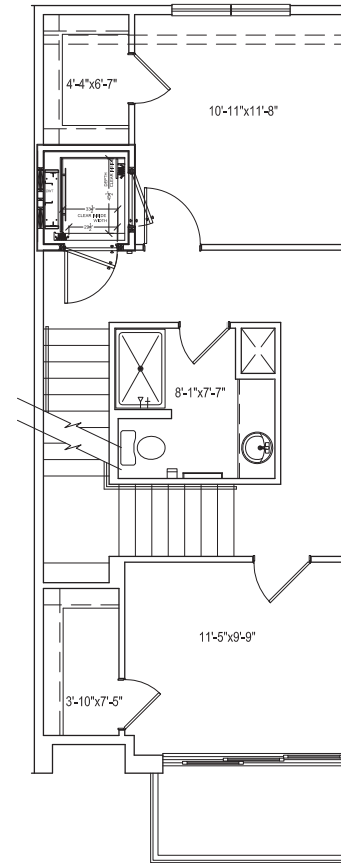
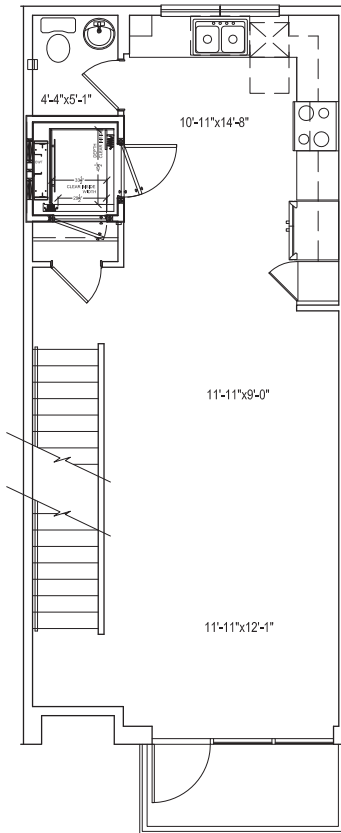
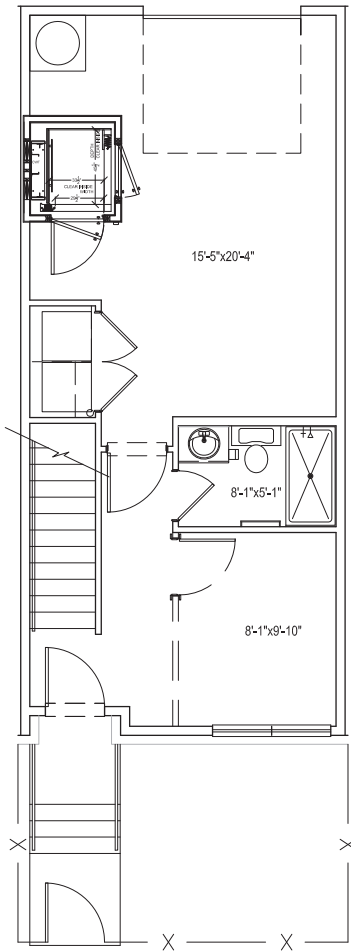

AMENITIES

- True fee simple, townhome ownership for lock and leave living without condo obligations or mortgage restrictions.
- All homes three-stories on individual lots.
- Limited HOA for common area landscaping and maintenance only.
- Sealed concrete first floors with hardwood second and third floors.
- Enclosed garages and storage per plan.
- Elevator capable per plan.
- Full complement of energy saving features.
- Fenced front or rear courtyards, per plan.
- Second and third floor balconies.
- Buyer selected interior finish and appliance packages.
- 9' first floor, 12' second floor and 10' third floor ceiling heights.
- Ample visitor parking.

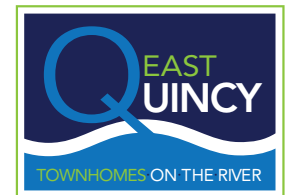

FOR AVAILABILITY
(210) 771-0334

Unit B

1,624 SF – 3 Bedroom – 3½ Bath

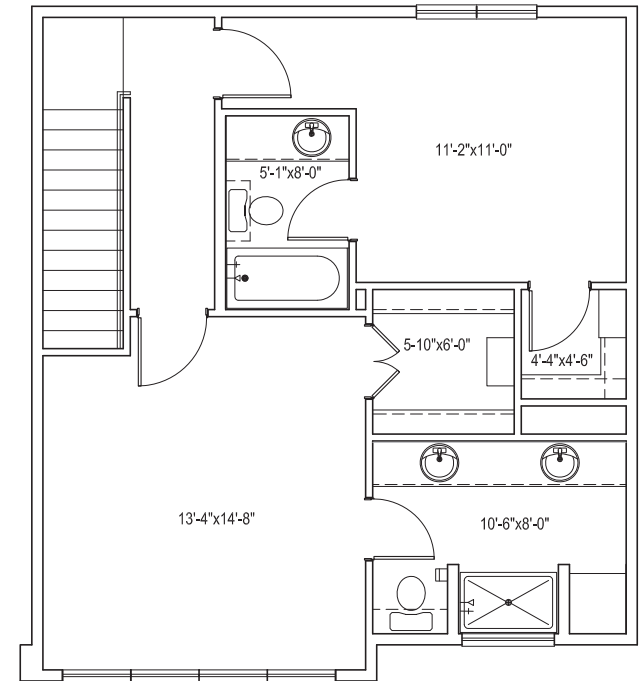
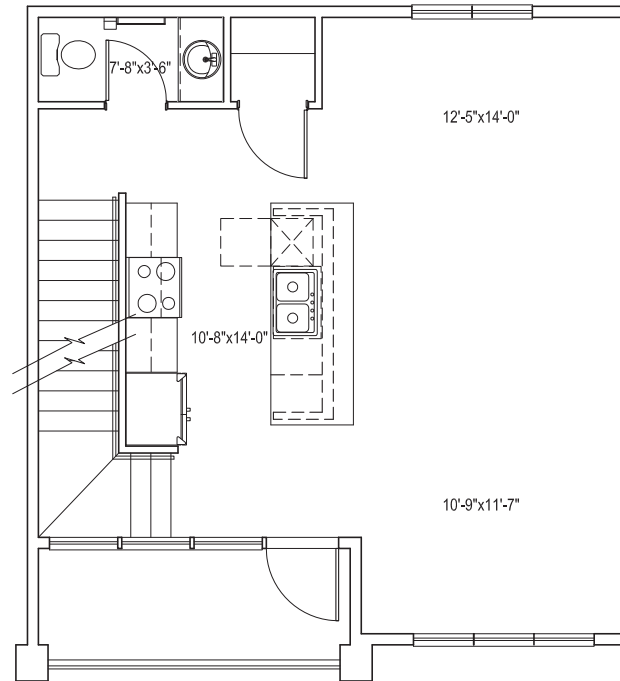
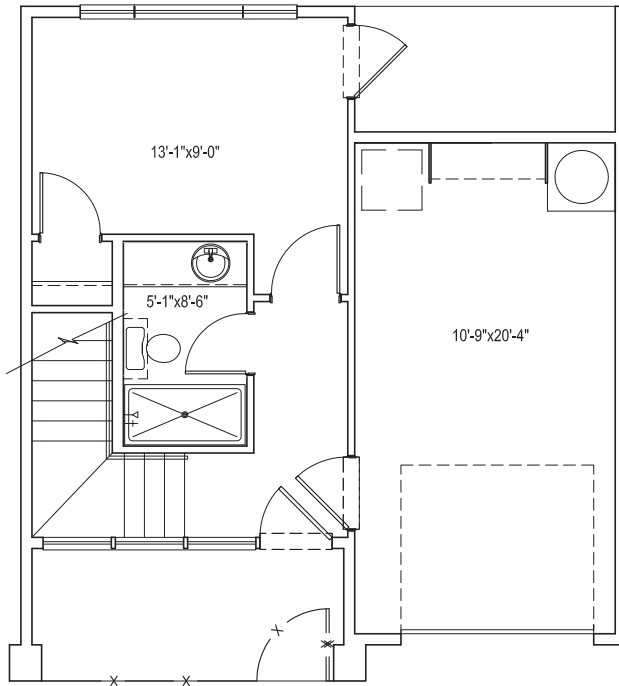

AMENITIES

- True fee simple, townhome ownership for lock and leave living without condo obligations or mortgage restrictions.
- All homes three-stories on individual lots.
- Limited HOA for common area landscaping and maintenance only.
- Sealed concrete first floors with hardwood second and third floors.
- Enclosed garages and storage per plan.
- Elevator capable per plan.
- Full complement of energy saving features.
- Fenced front or rear courtyards, per plan.
- Second and third floor balconies.
- Buyer selected interior finish and appliance packages.
- 9' first floor, 12' second floor and 10' third floor ceiling heights.
- Ample visitor parking.

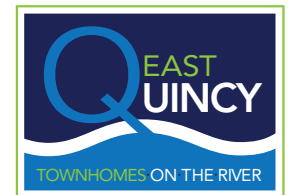

FOR AVAILABILITY
(210) 771-0334

Unit C

913 SF – 1 Bedroom – 1 Bath

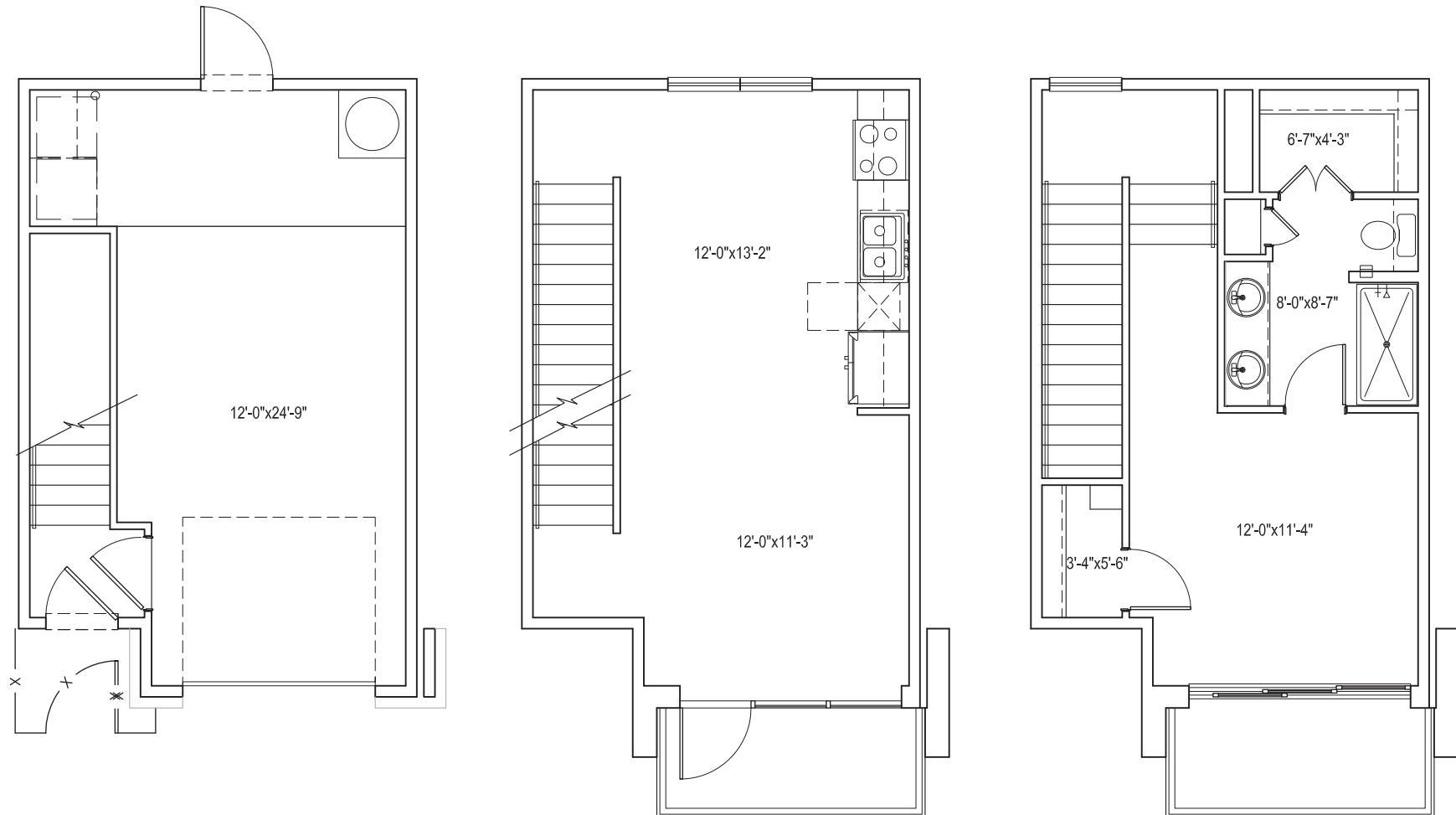

AMENITIES

- True fee simple, townhome ownership for lock and leave living without condo obligations or mortgage restrictions.
- All homes three-stories on individual lots.
- Limited HOA for common area landscaping and maintenance only.
- Sealed concrete first floors with hardwood second and third floors.
- Enclosed garages and storage per plan.
- Elevator capable per plan.
- Full complement of energy saving features.
- Fenced front or rear courtyards, per plan.
- Second and third floor balconies.
- Buyer selected interior finish and appliance packages.
- 9' first floor, 12' second floor and 10' third floor ceiling heights.
- Ample visitor parking.

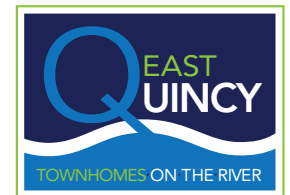

FOR AVAILABILITY
(210) 771-0334

Unit D

1,892 SF – 3 Bedroom – 3½ Bath

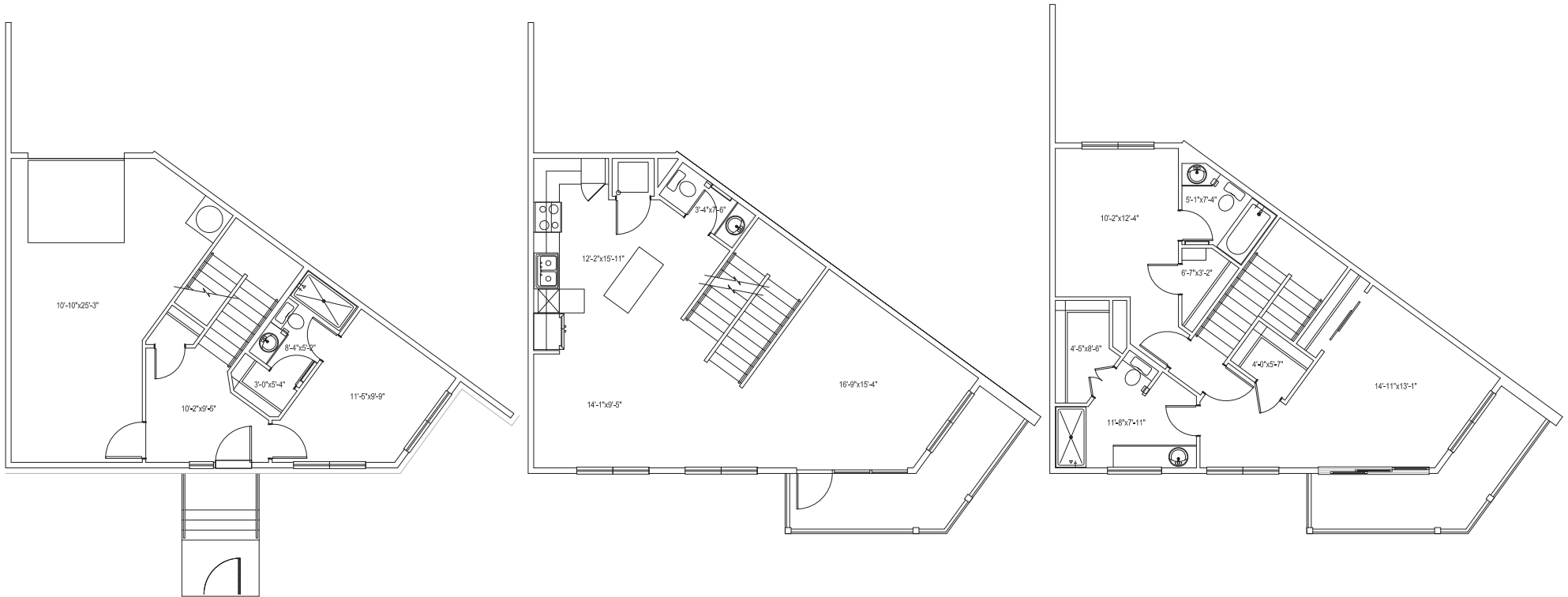

AMENITIES

- True fee simple, townhome ownership for lock and leave living without condo obligations or mortgage restrictions.
- All homes three-stories on individual lots.
- Limited HOA for common area landscaping and maintenance only.
- Sealed concrete first floors with hardwood second and third floors.
- Enclosed garages and storage per plan.
- Elevator capable per plan.
- Full complement of energy saving features.
- Fenced front or rear courtyards, per plan.
- Second and third floor balconies.
- Buyer selected interior finish and appliance packages.
- 9' first floor, 12' second floor and 10' third floor ceiling heights.
- Ample visitor parking.

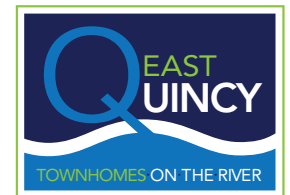

FOR AVAILABILITY
(210) 771-0334

Unit E

1,961 SF – 3 Bedroom – 3½ Bath

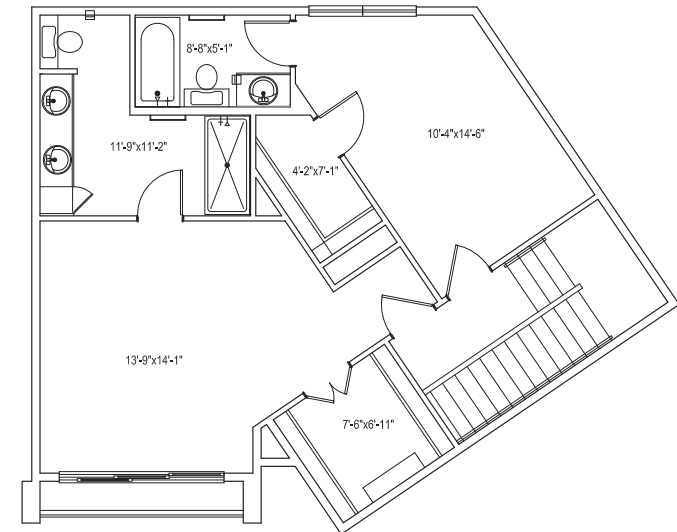
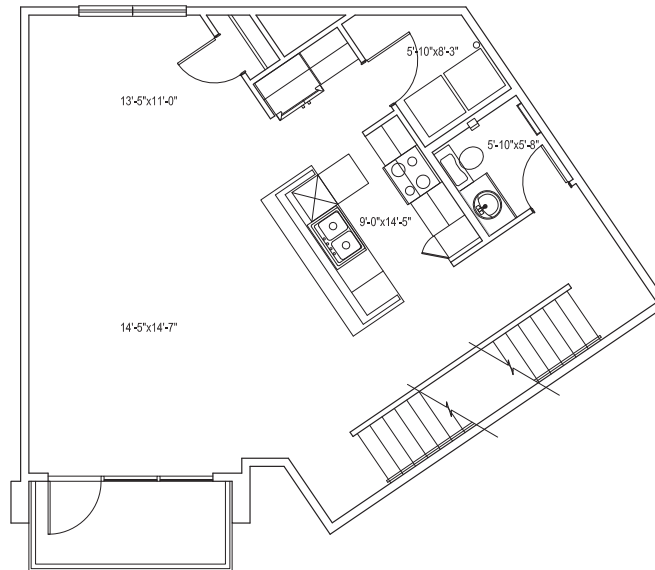
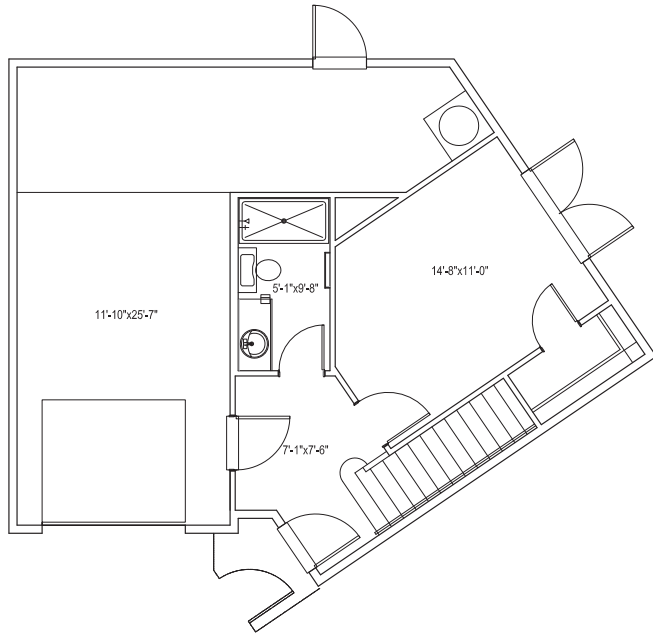

AMENITIES

- True fee simple, townhome ownership for lock and leave living without condo obligations or mortgage restrictions.
- All homes three-stories on individual lots.
- Limited HOA for common area landscaping and maintenance only.
- Sealed concrete first floors with hardwood second and third floors.
- Enclosed garages and storage per plan.
- Elevator capable per plan.
- Full complement of energy saving features.
- Fenced front or rear courtyards, per plan.
- Second and third floor balconies.
- Buyer selected interior finish and appliance packages.
- 9' first floor, 12' second floor and 10' third floor ceiling heights.
- Ample visitor parking.

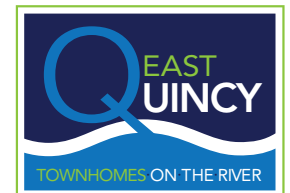

FOR AVAILABILITY
(210) 771-0334